



HBN65 Series

Technology



Uses infrared sensors to monitor heat from the cooking surface and automatically adjusts hood fan speed



Wi-Fi, Bluetooth and voice activation capabilities enable hands-free operation



Code Ready Technology® can limit airflow to 300 or 400 CFM to comply with local make-up air code requirements



EZ Install bracket system allows for single-person installation

Features

- Internal blower system powers 650 Max CFM, with less than 0.3 sones at low speed
- Perimeter aspiration with mesh filters engineered to optimize capture efficiency



Compatible with the BEST Kitchen Mobile App

best®

PERFORMANCE THAT INSPIRES

At **BEST**, we make high performance range hoods that perform beautifully. Astonishingly quiet. Impressively effective. Remarkably efficient. And perfectly suited for the most distinguished kitchens.

Whether it's the centerpiece of the room or letting its surroundings shine, **BEST** is where high-end performance inspires.

Installation height above the cooking surface: 24"-30" *

Dimensions shown in inches.

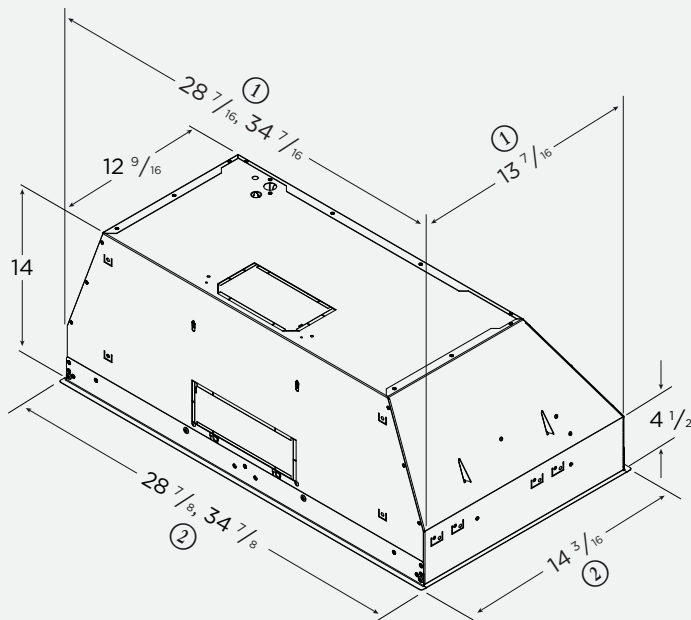

Note: Specification drawing dimensions and cutout dimensions assume the use of all four trims around the unit. **Front and back trims can be removed. Side trims are not removable.**

① Top width and depth measurements on the specification drawing include the screws/rivets that hold the trims in place.

② Bottom width and depth measurements on the specification drawing include the trims and indicate the true width and depth of the entire unit.

* Exceeding 30" installation height is the installer's choice and may result in reduced capture. Add 100 CFM for every 3" above this height.



HBN65 SERIES CUTOUT DIMENSIONS

Model	Cutout W x D
HBN65306SS	28 1/2"W x 13 5/8"D
HBN65366SS	34 1/2"W x 13 5/8"D

Note: HBN65 series hoods offer standard width dimensions. For retrofit applications of HBN65306SS, width adjustments will be needed to existing cutouts of discontinued CC65128SB units. The height of HBN65 units is 14", which is 3" more than CC65 units.

HOOD SIZES*

Internal Blower, Single - Depth: 14 3/16"

30" HBN65306SS

36" HBN65366SS

* For exact dimensions, please refer to installation, use and care instructions.

FEATURES

Finish	Brushed Stainless Steel (Grade 430)
Lighting Type	LED Modules (6W per module)
Number of Modules	2
Lighting Levels	4
Lighting Modules Included	Yes
Control Type	4-speed Capacitive Touch Slider
Control Features	Heat Sentry™, Delay-off, Wi-Fi/Bluetooth Connectivity, Voice Control, SmartSense, Filter Clean Reminder
Remote Control	BEST Kitchen app
Filter Type	Perimeter with Mesh
Non-ducted Capability	No

HOOD BLOWER INCLUDED

Max Blower CFM* 650

* Max Blower CFM indicates the performance of the hood blower in open air and is not HVI certified.

ACCESSORIES

ADA Kit	HAWRK5
Universal MUA Damper	MD8TU
Power Cord Kit	HCK44

INSTALLATION REQUIREMENTS

Amps @ 120V	3.8
Electrical Connection	Direct Wire
Duct Size	8" or 3 1/4" x 10"
Duct Direction	Vertical (round) or Horizontal (rectangular only)
Backdraft Damper	Included

HVI PERFORMANCE

SONES					
Speed	1 (0.01 in. w.g.)	2*	3*	4 (0.1 in. w.g.)	
8" round Vertical	< 0.3	0.8	3.0	9.0	
3 1/4" x 10" Horizontal	< 0.3	0.9	3.0	9.0	

CFM					
Speed	1 (0.01 in. w.g.)	2*	3*	4 (0.25 in. w.g.)	4 (0.1 in. w.g.)
8" round Vertical	130	180	290	590	610
3 1/4" x 10" Horizontal	120	170	280	560	580

* Where noted performance rating is not HVI certified.

AIRFLOW PERFORMANCE

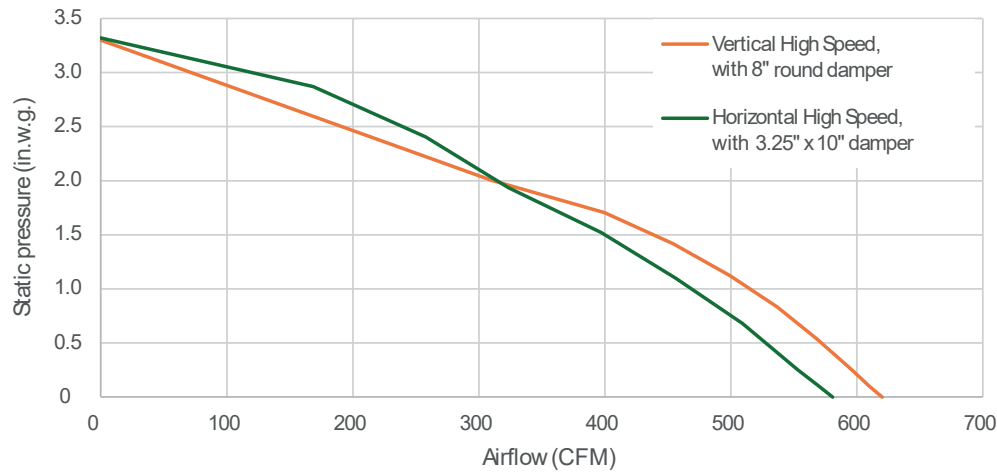

HVI-2100 CERTIFIED RATINGS comply with new testing technologies and procedures prescribed by the Home Ventilating Institute, for off-the-shelf products, as they are available to consumers. Product performance is rated at .01 in. and 0.25 in. static pressure at high speed based on tests conducted in an HVI-approved state-of-the-art test laboratory. Sones are a measure of humanly-perceived loudness, based on laboratory measurements.