



Baldwin

KNOB &

LEVER LAUNCHES

AGENDA

Knobs

- Overview
- Selling Features
- Details
- Sell the Suite

Levers

- Overview
- Selling Features
- Details
- Sell the Suite

Pricing & SKU List

Basics

- What's in the Box
- How to Order

Key Dates

Selling Tools/ Information

Marketing Support

A LOOK AT SCALE

Baldwin's latest product launch redefines luxury through precision in scale. As door sizes and design needs evolve, customization becomes the ultimate expression of sophistication. Every millimeter matters—ensuring a perfect fit for every style and space.



LUXURY IN KNOB SIZING

MINNEAPOLIS

5055 2-1/8" Knob
5046 Rose



NEW



5079 2 3/8" Knob

BALTIMORE

5000 2" Knob
5048 Rose



NEW



5083 2 1/2" Knob

NASHVILLE

5068 2-3/8" Knob
5070 Rose



NEW



5087 2" Knob

NEW



5088 2-5/8" Knob

SCALE MATTERS

The Why?

CUSTOM LUXURY, NOW STANDARD

We seamlessly blend a custom luxury aesthetic with standard options, offering a versatile and tailored design experience. Unique to our brand, this positions us ahead of Emtek and other non-luxury competitors.

ADAPTING TO EVOLVING DOOR DESIGNS

Our knobs and roses are designed to accommodate increasing door heights and sizes, ensuring they meet current design standards.

EXPANDED TIMELESS DESIGNS

Our best-selling, timeless styles now come in an expanded range, providing more choices for discerning clients. The proven sales of our top-selling Hollywood Hills knob, available in three sizes, consistently showcases a spread of market demand

VERSATILE DESIGN FOR EVERY STYLE

We offer a wide variety of knobs to suit any design style—modern, traditional, or transitional—providing flexibility to create a cohesive, unified look across any space.

AGING IN PLACE

Larger knobs accommodate aging in place, enhancing ease of use for elderly clients.

BALDWIN



PRODUCT DETAIL

Its All in the Details

5079 Minneapolis Knob

- 5046 Rose Passage and Dummy
- 5146 Rose for Privacy
- Adjustable Latch included at launch
- Finishes: 044, 055, 056, 076, 102, 112, 190, 260

5083 Baltimore Knob

- 5070 Rose Passage and Privacy Sets
- 5123 Rose For Privacy Sets
- Adjustable Latch included at launch
- Finishes: 003, 031, 033, 044, 055, 056, 076, 102, 112, 190, 260

5087 & 5088 Nashville Knobs

- 5070 Rose for Passage and Dummy sets
- 5123 Rose for Privacy Sets
- Adjustable Latch included at launch
- Finishes: 003, 031, 033, 044, 055, 056, 076, 102, 112, 190, 260

A La Carte available for Single and Pair of Knobs in all 14 finishes.



DETAILS

Line Art from Price Book

5079.xxx Minneapolis 2 3/8"

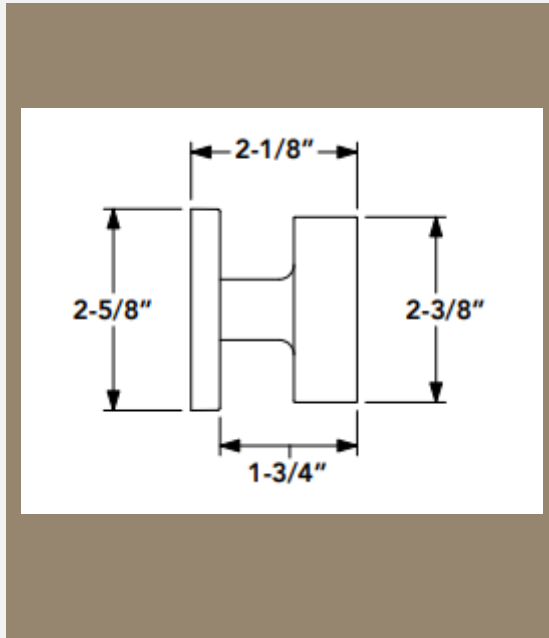

5083.xxx Baltimore 2 1/2"

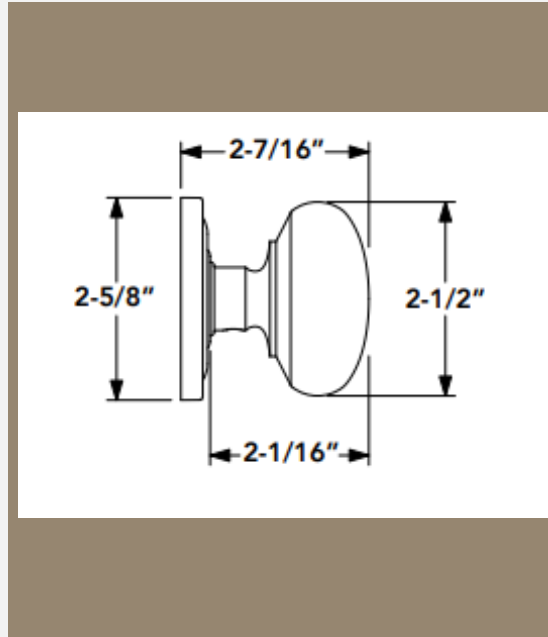

5087.xxx Nashville 2"

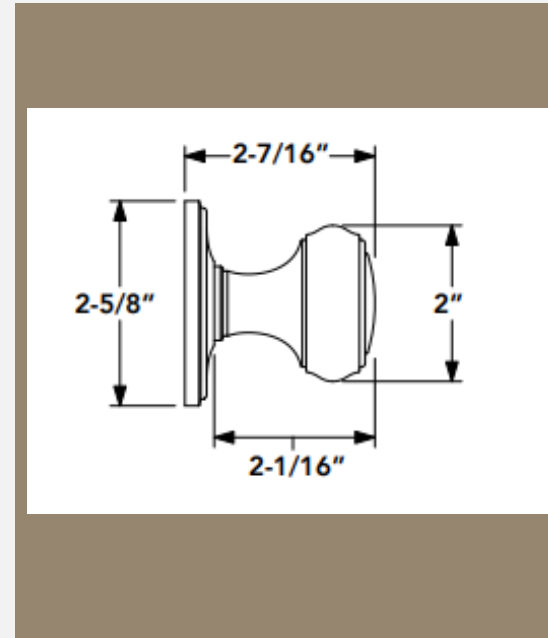

5088.xxx Nashville 2 5/8"

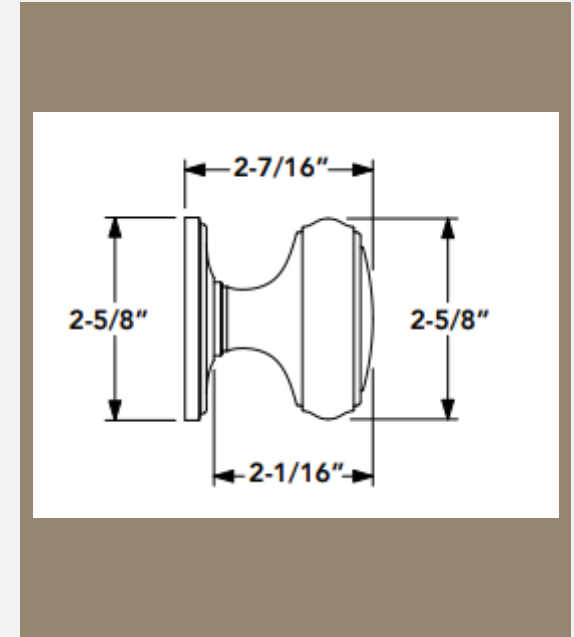

SELL THE SUITE

More than Just Knobs

Minneapolis:

- Minneapolis Mortise & Tubular Entry
- R048 Mid Century Plate
- 5056/R017 Square Rosettes
- 5006/5032/5046/R058 Round Rosettes
- 5162 Lever
- 0421 and 0423 ER Trim
- Santa Monica Multi Point and Pocket Door
- Contemporary Cabinet Collection

Baltimore:

- Baltimore Mortise Entry
- Stonegate Tubular
- 5002/R057/5017/5048 Rosettes
- R035 Arched Plate
- Cody and Boulder Multi Point
- 5106 or 5455V levers
- Severin A Cabinet Hardware

Nashville:

- Nashville Mortise
- Hollywood Hills Entrance trims
- 5010/5070 Rosettes
- L034 and 5116 levers
- Palo Alto Pocket Hardware
- Hollywood Hills Cabinet

PUSHING CUSTOMIZATION

A look at Scalable Options in Our Portfolio

Hollywood Hills



- First Proven Set of Scaled Knobs
- K007 2" Knob
- K008 2.25" Knob
- K009 2.5" Knob
- Hollywood Hills Rosettes- R049, R050, R051, R053

Rose Options



- 5002, 5017, 5048, 5148 Rosettes
- 5006, 5032, 5139, 5046, 5146 Rosettes
- 5010, 5151, 5070, 5123 Rosettes
- 5028, 5075, 5127, 5155 Rosettes
- Bethpage Rosettes- R027, R029, R054
- Arch Rosettes- R030, R032, R055
- Contemporary Rosettes- R017, R048, R052
- Bevel Rosettes- R033, R035, R056

TRADITIONAL TO TRANSITIONAL

With a 78-year legacy of exceptional traditional design and impeccable quality, Baldwin continues to honor its heritage while embracing innovation. Our newest lever designs blend timeless craftsmanship with fresh, transitional details that redefine modern elegance.

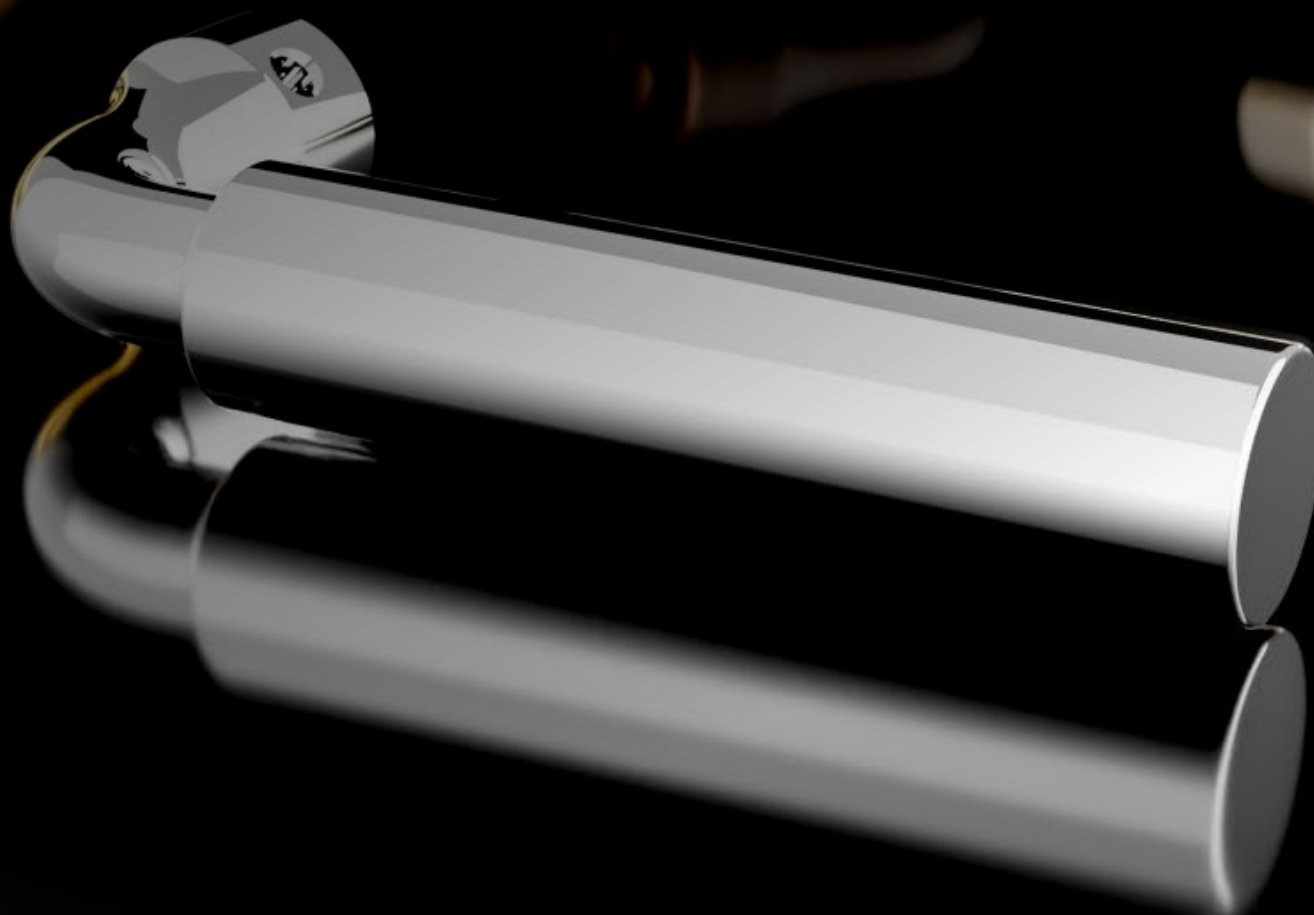

NEW LEVERS

**Curved Gramercy:
L031 Lever w/ 5046 Rose**

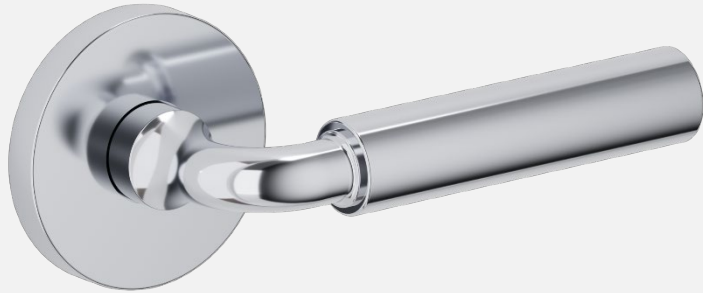

**Briarcrest Lever:
L033 Lever w/5070 Rose**

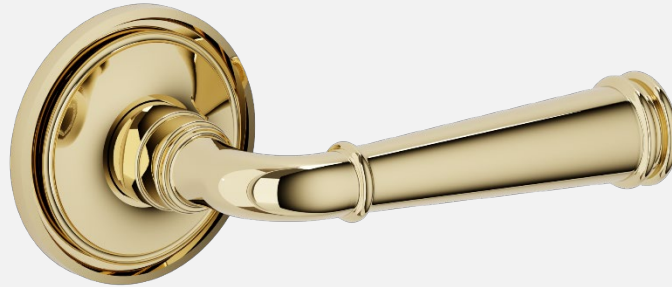

**Nashville Lever:
L034 Lever W/ 5078 Rose**



NEWNESS IN DESIGN

The Why

INNOVATIVE DESIGNS LIKE NEVER BEFORE

We're bringing fresh, groundbreaking creations from Baldwin, ensuring there's always something new to talk about while continuously meeting evolving market needs.

HONORING BALDWIN'S RICH HERITAGE

With a strong legacy in traditional design, we've thoughtfully expanded the portfolio and rounded out Baldwin needs. Now we take a moment to honor our roots, paying homage to the timeless design language that defines Baldwin.

UNPARALLELED ATTENTION TO DETAIL

From crisp corners to meticulously crafted lever designs, our focus on precision sets us apart from non-luxury brands in the market.

DEFINING THE "NEW TRADITIONAL"

New Traditional blends classic elegance with modern flair, merging traditional silhouettes with updated finishes and details to create a refined look that speaks to both tradition and innovation. An on trend solution for Baldwin customers.

BALDWIN



NEW TRADITIONAL

Creating A Mix Of Bespoke Elements To Evoke Warmth

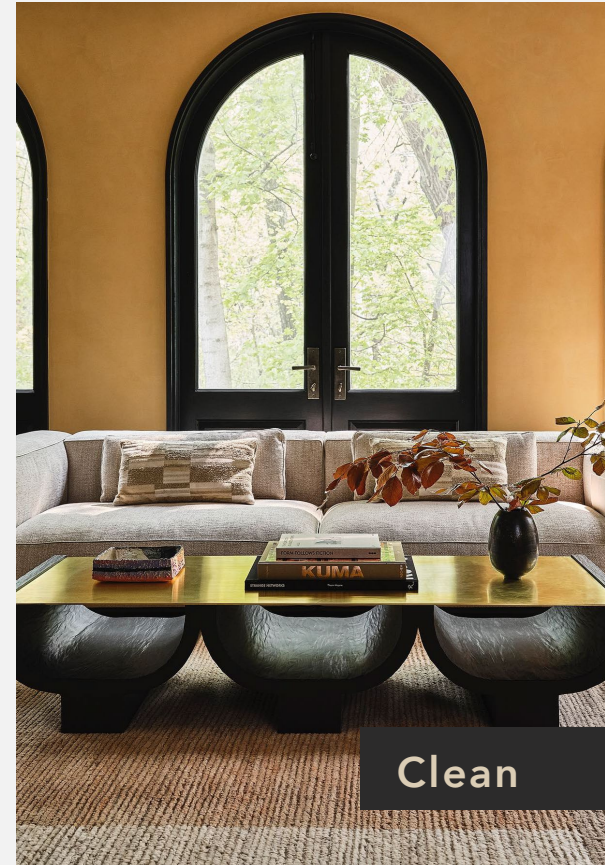

PRODUCT OVERVIEW

Its All in the Details

L031 CURVED GRAMERCY

- 5046 Rose For Passage and Dummy
- 5146 Rose for Privacy

L033 BRIARCREST LEVER

- 5070 Rose for Passage and Dummy
- 5123 Rose for Privacy

L034 NASHVILLE LEVER

- 5078 Rose for Passage and Dummy
- 5134 Rose for Privacy

LEVERS PRE-CONFIGURED

- All Three Launch With the 6507.009 Adaptor
- All Three Launch with the Same 11 Finish Options
- Adjustable Latch and Dual Strike



DETAILS

Line Art from Price Book

L031 Curved Gramercy

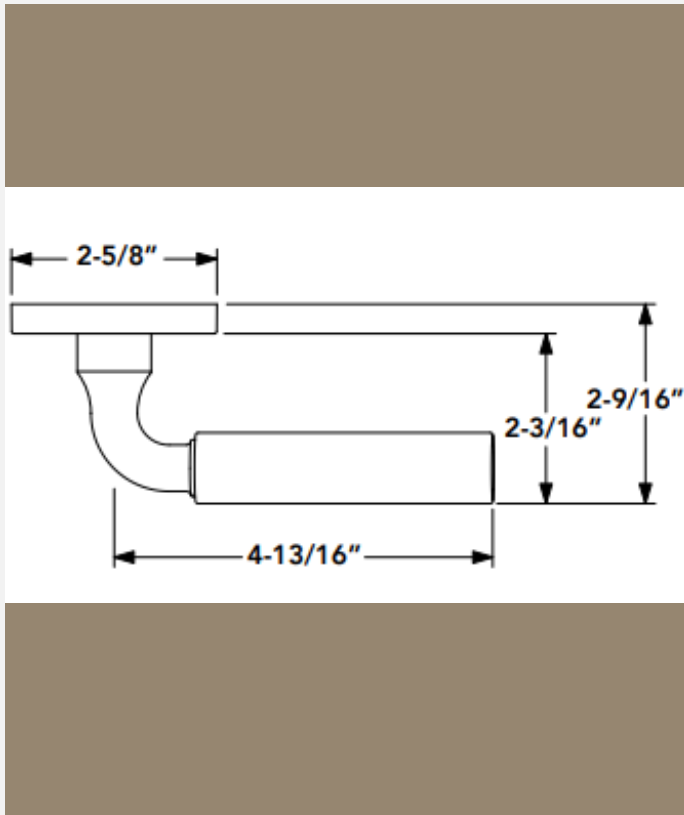

L033 Briarcrest

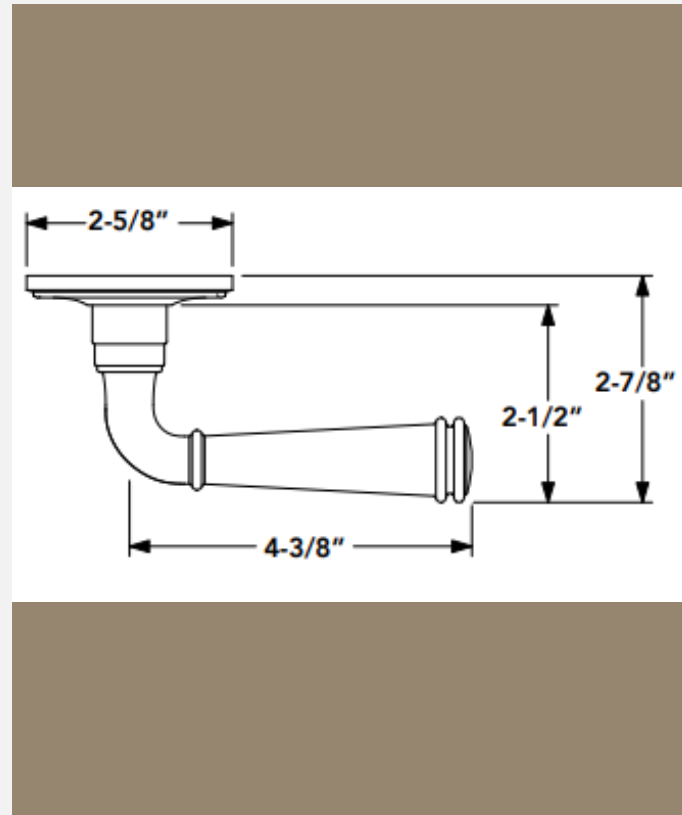

L034 Nashville

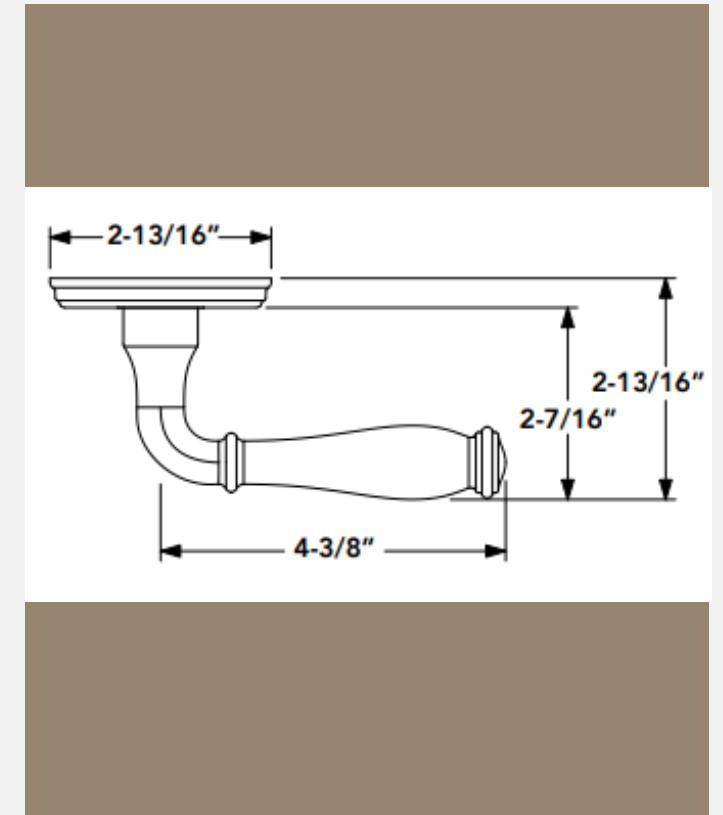

SELL THE SUITE LEVERS

Complimentary Hardware Already available

Curved Gramercy

- Gramercy Entrance Trim
- Hollywood Hills Entrance trims
- 5006/5032/5046/R058 Roses
- 5056/R017/R053/R048 Roses
- Santa Monica Pocket Trim
- Gramercy Cabinet
- Hollywood Hills Cabinet Pulls



BALDWIN

Briarcrest

- Concord Mortise
- Cody Tubular Trim
- 5010/5070 Rosettes
- 5069/K012 Knobs
- Severin Fayerman Collection C Cabinet Knobs



Nashville

- Nashville Mortise
- Hollywood Hills Entrance trims
- 5010/5070 Rosettes
- 5087, 5068 and 5088 Knobs
- Palo Alto Pocket Hardware
- Hollywood Hills Cabinet



OLD . BALDWIN

LIST PRICE

Simplified Structure for Ease of Selling

Large Knobs	PASS	PRIV	IDM	FD	MR	IMR
5079, 5083 and 5088	\$433	\$433	\$173	\$346	\$290	\$145
Small Knob	PASS	PRIV	IDM	FD	MR	IMR
5087	\$380	\$380	\$152	\$304	\$230	\$115
Levers	PASS	PRIV	IDM	FD	MR	IMR
L031, L033 & L034	\$433	\$433	\$173	\$290	\$230	\$145

WHAT'S IN THE BOX



*Shown here: 5079.190.PASS

Included in Pre-Configured:

- Pair of Two Knobs
- Pair of Two Roses
- 5540 Adjustable Backset Latch
- 5510.xxx.TSTR Standard Box Strike (T Strike)
- 5510.xxx.FSTR Full Lip Strike
- Spindle
- 6503.009 Door Adapter
- (2) Rose Retainers
- (2) Nylon Washers
- Rose Retainer Wrench
- Universal Dust Box
- (4) Fasteners Latch & Strike
- (4) Set Screws
- (2) Fasteners Adaptor
- Installation Instructions
- Drill Instructions
- 2.1/8" Door Prep Template

Privacy also includes:

- Privacy Pin
- Pre-Installed Privacy Screw & Spacer
- Emergency Key & Push Pin extender

HOW TO ORDER A LA CARTE

The Basics: Tubular Interior Rose Options

KNOBS OR LEVERS

Select a pair or an individual knob or lever



5088.056.MR



ROSES

Select a passage or privacy rose



5070.056.PS/PV



LATCH

Select a passage or privacy latch
No need to specify knob or lever strength, full lip or t-strike



5540.056/5540.056.P



ADAPTOR

Select appropriate adaptor
*see adaptor chart in pricebook to determine proper adaptor



6503.009



KEY DATES

ACTIVITY

Customer Video & Deck

DATE

Week of 9/23

TAKE ORDER DATE

10/1

Showroom Monthly Email

Week of 10/18

COMMERCIALIZATION DATE

10/ 21

Sell Sheets

Week of 10/21

Website & Digital Marketing Plan

Week of 10/21

QUICK SHIP AVAILABILITY

11/1

ASSETS

To be Delivered the week of 10/21

Clipped



Vignette



Beauty



Video

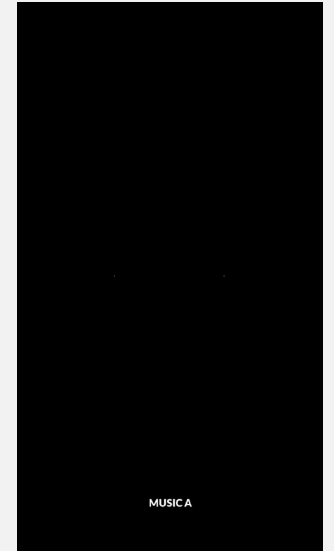

SELLING TOOLS



DETAILS

- Customer PowerPoint & Customer Video
- Sell Sheet- Trifold Knob
- Sell Sheet- 1 Pager Lever Focus
- Images & Videos
- Digital Asset Plan

BRAND TOUCH POINTS

Luxe Announcement Ad

- Launching October/ November Issue of Luxe Magazine Nationwide

Luxe Native Article

- Launching Late October: Scale Matters in Design- Advertorial featuring Theresa Ory on how she uses scale in her Bathroom of the Year Winner

Press Release & Press Appointments

- Press Release is launching 10/1

Launch Event

- 10/5 Nashville Designers Launch Event at Design Edge

Material Bank

- Sample on Material Bank December

BALDWIN



DIGITAL PLAN

Website

- Week of 10/21
 - Carousel Update
 - Products Live on Site
- Digital Awareness Spend Plan

Social

- 10/22- Instagram Launch
- Pinterest & LinkedIn to follow
- Digital Spend Plan for Social

Email

- 10/18- Showroom Email
- 10/21- Launch Email
- 10/28- Luxury A & D Email

Digital Asset Box for Showrooms

- 10/20- Marketing Launch Videos
- 11/1- Ready

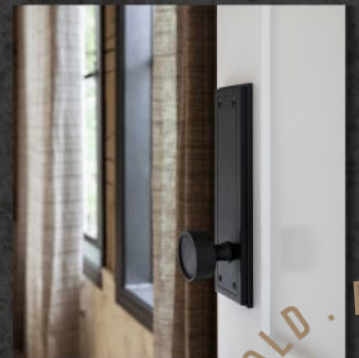
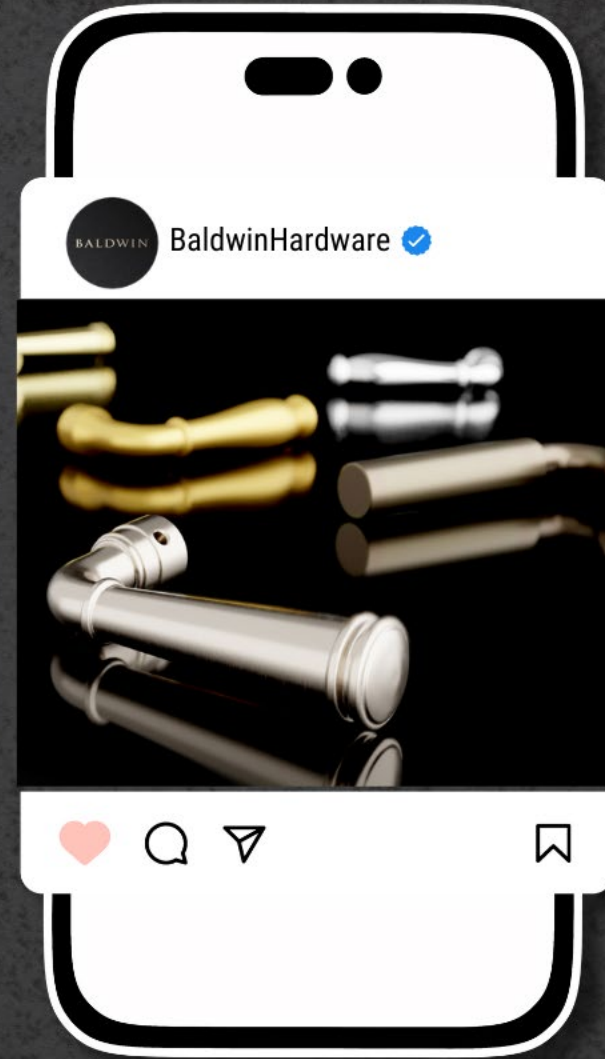

If you have any questions,
please reach out to your
Baldwin sales
representative





THANK YOU