



Under-Counter

Double Drawer Panel
Comparison

Thermador[®]

Double Drawer Units

900 Series

Top View

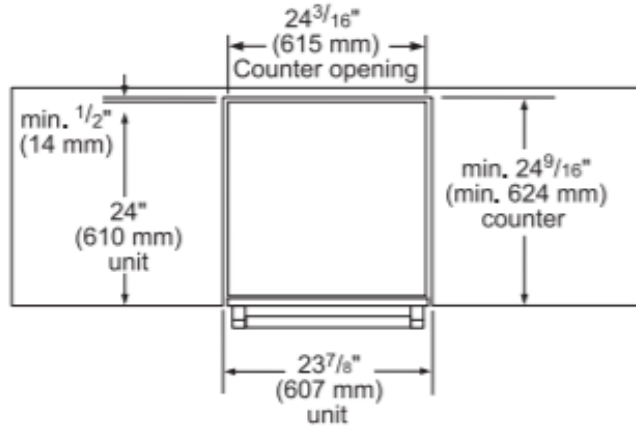

Thermador double drawer under counter top dimension.
(Unit door flushed with the cutout)

measurements in inches (mm)

Frontal view

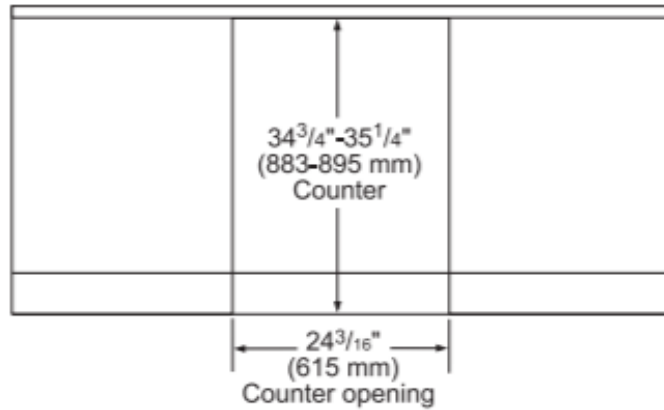

measurements in inches (mm)

905 Series

Top View

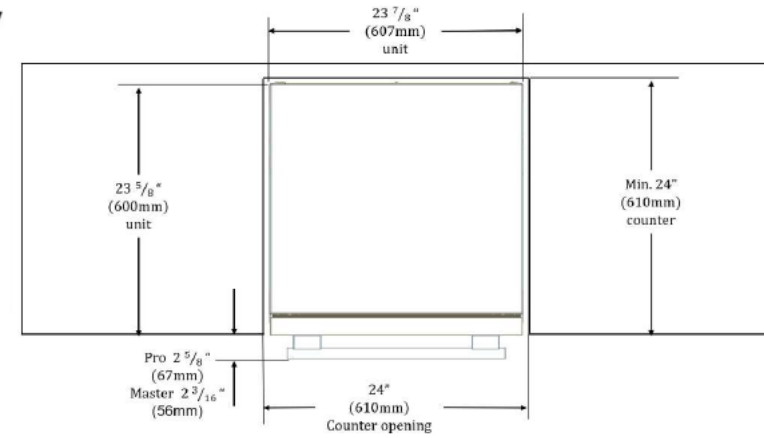

Thermador double drawer under counter top dimension.
(Unit door flushed with the cutout)

Measurements in inches (mm)

Frontal view

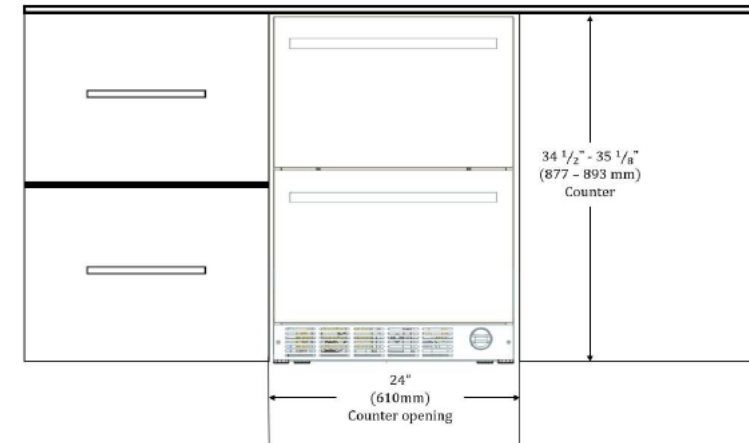

measurements in inches (mm)

Top Drawer 800 series

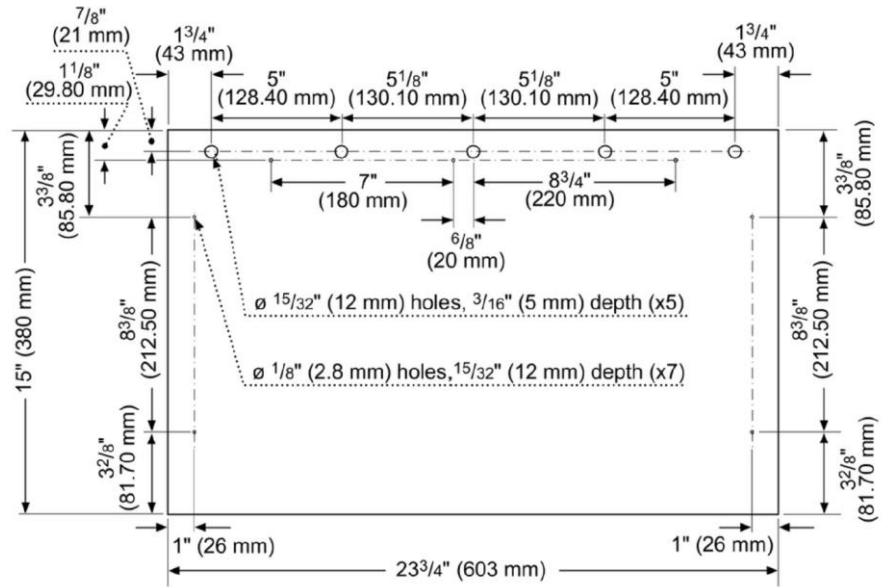

Top Drawer 900 series



Bottom Drawer 800 series

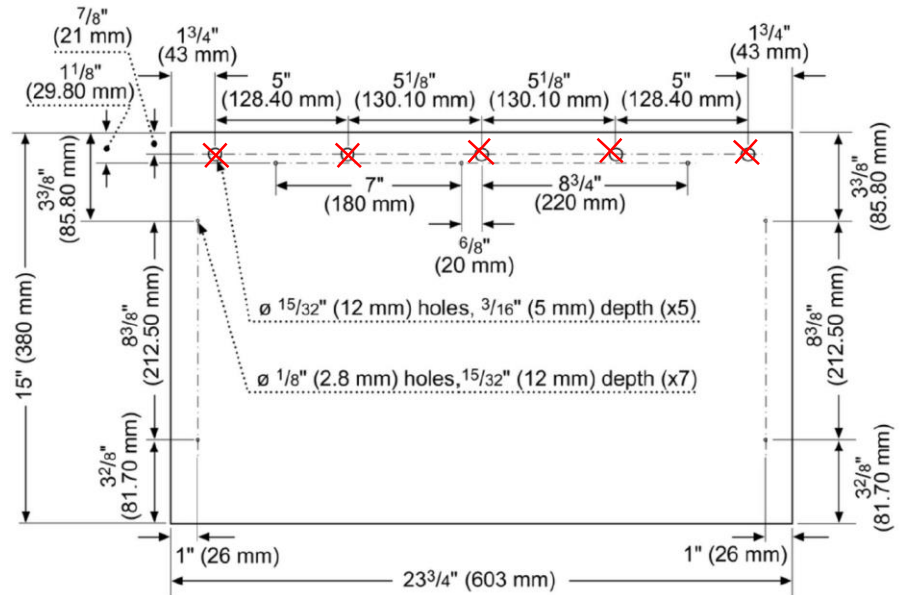

Notes:

1. The $\varnothing 15/32"$ (12 mm) holes are only needed in the top panel. Bottom panel does not need these holes.

Bottom Drawer 900 series



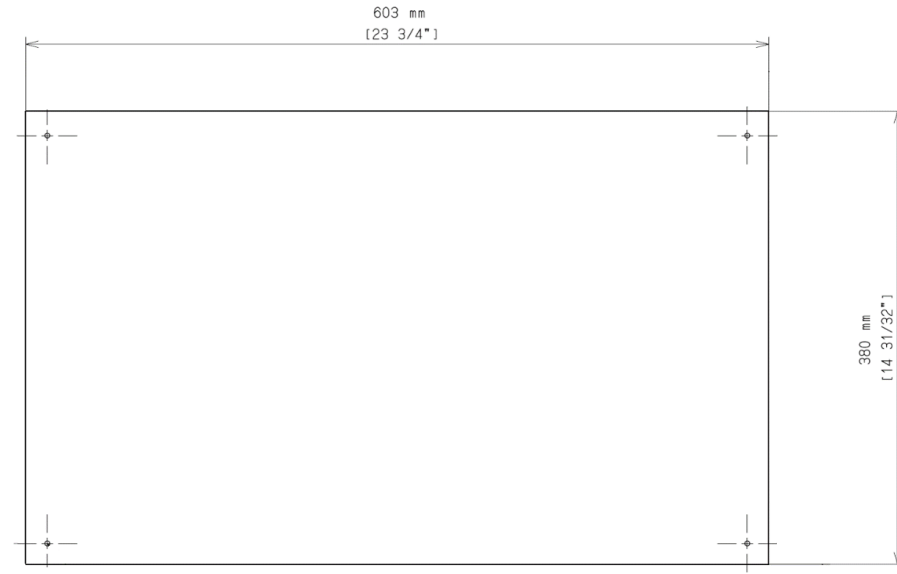
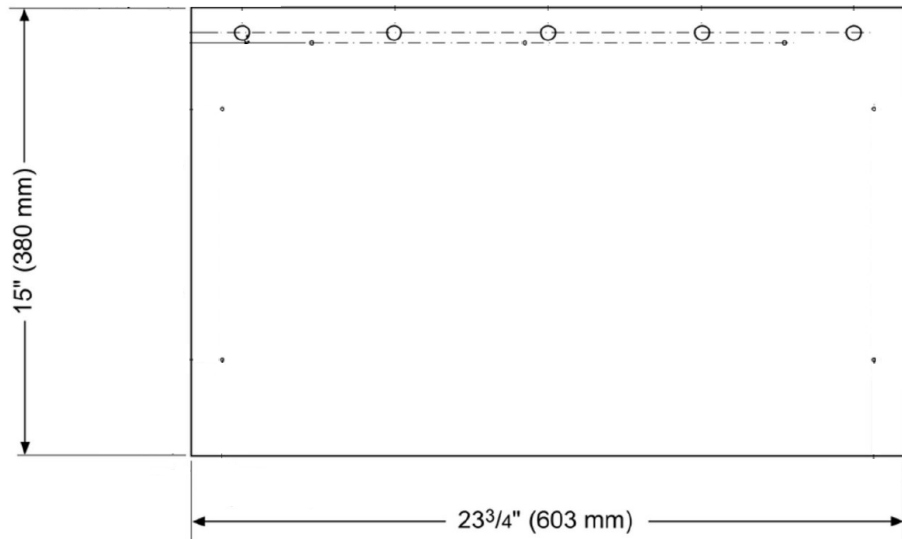

Total panel dimensions changes are as follows:

Height: no change 380 mm
(14 31/32" is more accurate than 15")

Width : no change 603 mm

Depth: no change 19 mm

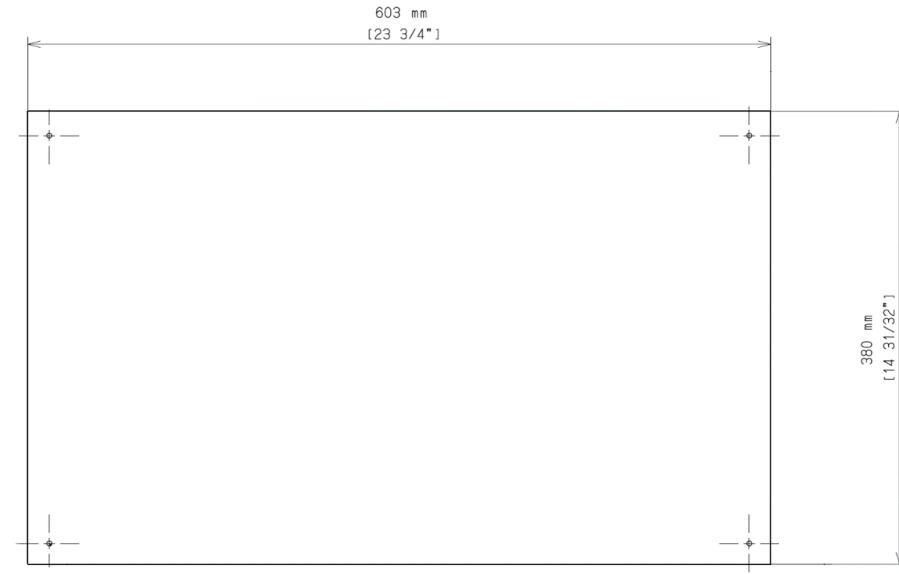
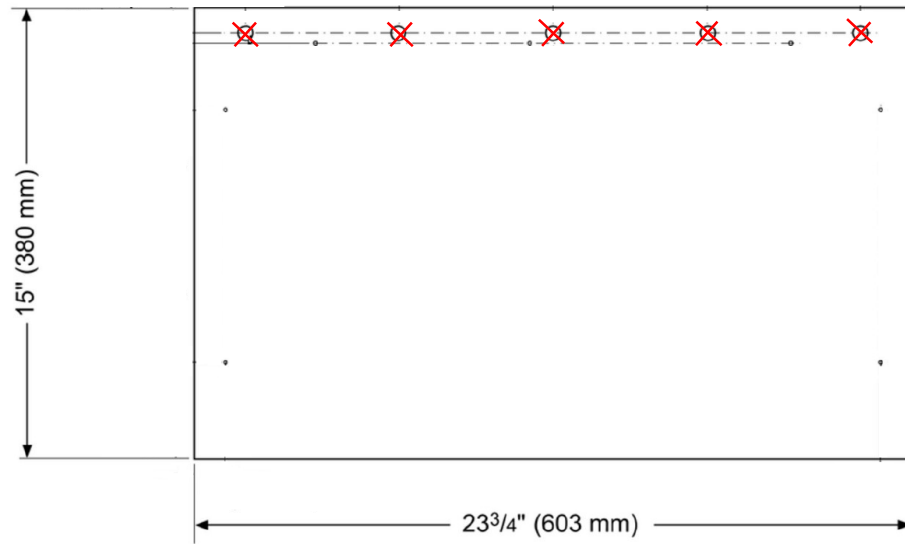

Total panel dimensions changes are as follows:

Height: no change 380 mm
(14 31/32" is more accurate than 15")

Width : no change 603 mm

Depth: no change 19 mm

TOP PANEL HOLES POSITIONS

800 series hole positions

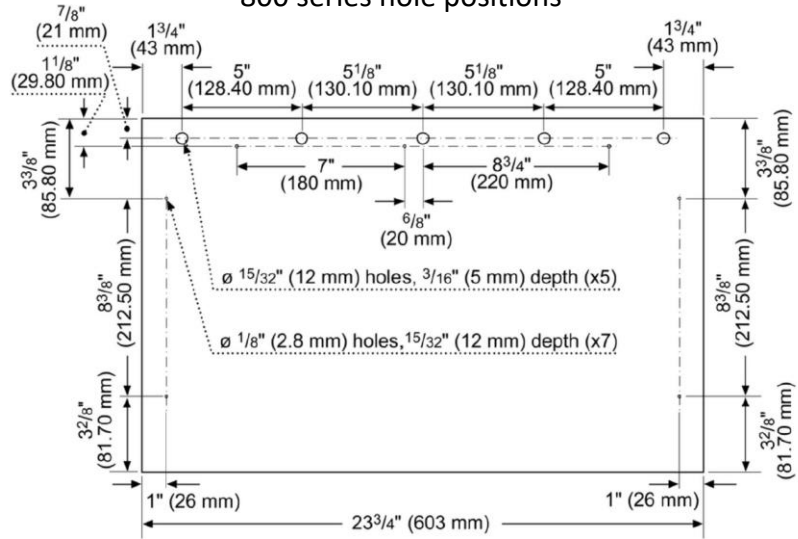

900 series



Top 12 mm holes are removed (5 holes)
 Top 2.8 mm holes are removed (3 holes)

After removing the top holes (For comparison only):

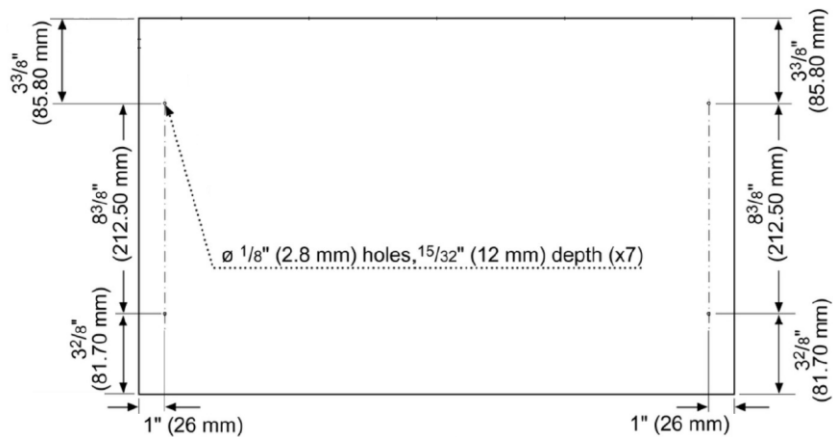

Distance to side edge (both sides): 26 mm to 17.5 mm
 Distance to top for upper holes: 85.8 mm to 20.5 mm
 Distance to bottom for bottom holes: 81.7 mm to 17.5 mm



THANK YOU!
