

VCI3B30ZS

30-INCH CUSTOM INSERT

MASTERPIECE® SERIES



FEATURES & BENEFITS

- Suitable for standard cabinet depth applications
- Four fan speeds
- Built-in 'clean filter' reminder light illuminates after 40 hours of operation
- Auto mode allows the hood to adjust its speed according to the cooking style
- Delayed shut-off tackles lingering odors for up to 10 minutes
- Powerfully quiet® ventilation systems
- Equipped with the Thermador Connected Experience by Home Connect™

ACCESSORIES (OPTIONAL)

Recirculation Kit	N/A
Replenishment Charcoal Filter Set	CHFVCI30ZS

Remote Control Panel

REMCPU - Ability to vertically install on cabinetry or wall to control hood in a convenient location



Installed in skirted cabinets

GENERAL PROPERTIES

Operating Mode	Ducted or Recirculating
Maximum CFM (Blower)	300 CFM
Motor Location	Integrated Motor
Number of Speed Settings	4-Stage
CFM (HVI)	260 HS / 100 WS
Sones (HVI)	3.5 HS / 0.3 WS
Number of Lights	2
Bulb Type	LED
Light Lumens	100 – 150
Light Color (°K)	3500 – 4000
Total Power of the Lamps	6 W
Damper Included	Yes
Grease Filter Material	Dishwasher Safe Aluminum
Grease Filter Type	Perimetric
Home Connect™ (Wi-Fi Enabled)	Yes

TECHNICAL DETAILS

Watts	159 W
Current	15 A
Volts	120 V
Frequency	60 Hz
Plug Type	Hardwire
Power Cord / Conduit Length	N/A

DIMENSIONS & WEIGHT

Overall Appliance Dimensions (Width of Canopy Included) (HxWxD) (in)	10 1/2" x 26 1/2" x 10 5/8"
Required Distance Above Gas / Electric Cooking Surface	24" Electric / 30" Gas
Diameter of Air Duct (Top)	6"
Net Weight	24 lbs.

WARRANTY

Limited Warranty Parts and Labor	2 Years
----------------------------------	---------



Installed in European style cabinets

PRELIMINARY PRELIMINARY PRELIMINARY PRELIMINARY PRELIMINARY PRELIMINARY PRELIMINARY PRELIMINARY PRELIMINARY PRELIMINARY

VCI3B30ZS

30-INCH CUSTOM INSERT

MASTERPIECE® SERIES



HOOD DIMENSIONS

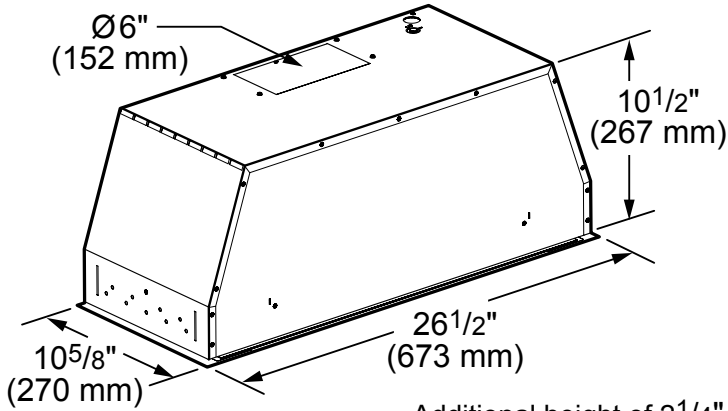

Additional height of 2 1/4" for the included damper to be considered.

measurements in inches and mm

CUTOUT FOR INSERT

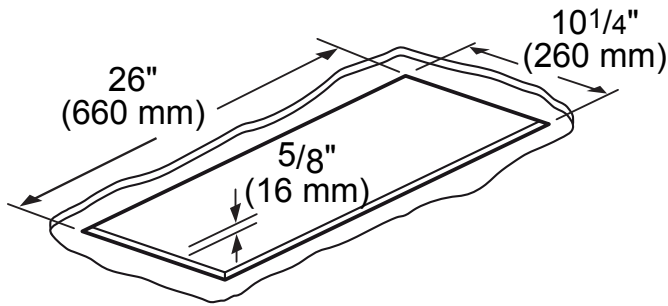

measurements in inches and mm

OPTIONAL ACCESSORIES

REMOTE CONTROL PANEL REMCPW



Convenience at your fingertips: The remote control accessory offers the freedom to extend your hood controls to a more reachable spot

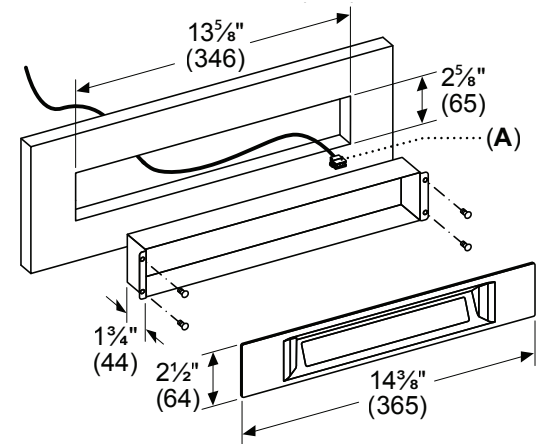

A: DBus Cable length: 30 feet (9180 mm)
measurements in inches (mm)

These warranties give you specific legal rights and you may have other rights that vary from state to state. Limited warranty from date of purchase. For complete warranty details, refer to your Use & Care manual, or ask your dealer.

Specifications are for planning purposes only. Refer to installation instructions and consult your countertop supplier prior to making counter opening. Consult with a heating and ventilation engineer for your specific ventilation requirements. For the most detailed information, refer to installation instructions accompanying product or write to Thermador indicating the model number. Specifications are correct at time of printing. Thermador reserves the right to change product specifications or design without notice. Some models are certified for use in Canada. Thermador is not responsible for products that are transported from the U.S. for use in Canada.

VCI3B36ZS

36-INCH CUSTOM INSERT

MASTERPIECE® SERIES



Image shown is not final



FEATURES & BENEFITS

- Suitable for standard cabinet depth applications
- Four fan speeds
- Built-in 'clean filter' reminder light illuminates after 40 hours of operation
- Auto mode allows the hood to adjust its speed according to the cooking style
- Delayed shut-off tackles lingering odors for up to 10 minutes
- Powerfully quiet® ventilation systems
- Equipped with the Thermador Connected Experience by Home Connect™

ACCESSORIES (OPTIONAL)

Recirculation Kit	N/A
Replenishment Charcoal Filter Set	CHFVCI36ZS
Remote Control Panel	
REMCPU - Ability to vertically install on cabinetry or wall to control hood in a convenient location	



Installed in skirted cabinets

GENERAL PROPERTIES

Operating Mode	Ducted or Recirculating
Maximum CFM (Blower)	300 CFM
Motor Location	Integrated Motor
Number of Speed Settings	4-Stage
CFM (HVI)	260 HS / 100 WS
Sones (HVI)	3.5 HS / 0.3 WS
Number of Lights	2
Bulb Type	LED
Light Lumens	100 – 150
Light Color (°K)	3500 – 4000
Total Power of the Lamps)	6 W
Damper Included	Yes
Grease Filter Material	Dishwasher Safe Aluminum
Grease Filter Type	Perimetric
Home Connect™ (Wi-Fi Enabled)	Yes

TECHNICAL DETAILS

Watts	159 W
Current	15 A
Volts	120 V
Frequency	60 Hz
Plug Type	Hardwire
Power Cord / Conduit Length	N/A

DIMENSIONS & WEIGHT

Overall Appliance Dimensions (Width of Canopy Included) (HxWxD) (in)	10 1/2" x 32 1/2" x 10 5/8"
Required Distance Above Gas / Electric Cooking Surface	24" Electric / 30" Gas
Diameter of Air Duct (Top)	6"
Net Weight	27 lbs.

WARRANTY

Limited Warranty Parts and Labor	2 Years
----------------------------------	---------



Installed in European style cabinets

VCI6B30ZS

30-INCH CUSTOM INSERT

MASTERPIECE® SERIES



Image shown is not final



FEATURES & BENEFITS

- Suitable for standard cabinet depth applications
- Four fan speeds
- Built-in 'clean filter' reminder light illuminates after 40 hours of operation
- Auto mode allows the hood to adjust its speed according to the cooking style
- Delayed shut-off tackles lingering odors for up to 10 minutes
- Powerfully quiet® ventilation systems
- Equipped with the Thermador Connected Experience by Home Connect™

ACCESSORIES (OPTIONAL)

Recirculation Kit	N/A
Replenishment Charcoal Filter Set	CHFVCI30ZS

Remote Control Panel

REMCPU - Ability to vertically install on cabinetry or wall to control hood in a convenient location



Installed in skirted cabinets

GENERAL PROPERTIES

Operating Mode	Ducted or Recirculating
Maximum CFM (Blower)	600 CFM
Motor Location	Integrated Motor
Number of Speed Settings	4-Stage
CFM (HVI)	520 HS / 170 WS
Sones (HVI)	10.5 HS / 0.8 WS
Number of Lights	2
Bulb Type	LED
Light Lumens	100 – 150
Light Color (°K)	3500 – 4000
Total Power of the Lamps	6 W
Damper Included	Yes
Grease Filter Material	Dishwasher Safe Aluminum
Grease Filter Type	Perimetric
Home Connect™ (Wi-Fi Enabled)	Yes

TECHNICAL DETAILS

Watts	338 W
Current	15 A
Volts	120 V
Frequency	60 Hz
Plug Type	Hardwire
Power Cord / Conduit Length	N/A

DIMENSIONS & WEIGHT

Overall Appliance Dimensions (Width of Canopy Included) (HxWxD) (in)	10 1/2" x 26 1/2" x 10 5/8"
Required Distance Above Gas / Electric Cooking Surface	24" Electric / 30" Gas
Diameter of Air Duct (Top)	8"
Net Weight	24 lbs.

WARRANTY

Limited Warranty Parts and Labor	2 Years
----------------------------------	---------



Installed in European style cabinets

VCI6B36ZS

36-INCH CUSTOM INSERT

MASTERPIECE® SERIES



Image shown is not final



FEATURES & BENEFITS

- Suitable for standard cabinet depth applications
- Four fan speeds
- Built-in 'clean filter' reminder light illuminates after 40 hours of operation
- Auto mode allows the hood to adjust its speed according to the cooking style
- Delayed shut-off tackles lingering odors for up to 10 minutes
- Powerfully quiet® ventilation systems
- Equipped with the Thermador Connected Experience by Home Connect™

ACCESSORIES (OPTIONAL)

Recirculation Kit	N/A
Replenishment Charcoal Filter Set	CHFVCI36ZS

Remote Control Panel

REMCPU - Ability to vertically install on cabinetry or wall to control hood in a convenient location



Installed in skirted cabinets

GENERAL PROPERTIES

Operating Mode	Ducted or Recirculating
Maximum CFM (Blower)	600 CFM
Motor Location	Integrated Motor
Number of Speed Settings	4-Stage
CFM (HVI)	520 HS / 170 WS
Sones (HVI)	10.5 HS / 0.8 WS
Number of Lights	2
Bulb Type	LED
Light Lumens	100 – 150
Light Color (°K)	3500 – 4000
Total Power of the Lamps	6 W
Damper Included	Yes
Grease Filter Material	Dishwasher Safe Aluminum
Grease Filter Type	Perimetric
Home Connect™ (Wi-Fi Enabled)	Yes

TECHNICAL DETAILS

Watts	338 W
Current	15 A
Volts	120 V
Frequency	60 Hz
Plug Type	Hardwire
Power Cord / Conduit Length	N/A

DIMENSIONS & WEIGHT

Overall Appliance Dimensions (Width of Canopy Included) (HxWxD) (in)	10 1/2" x 32 1/2" x 10 5/8"
Required Distance Above Gas / Electric Cooking Surface	24" Electric / 30" Gas
Diameter of Air Duct (Top)	8"
Net Weight	27 lbs.

WARRANTY

Limited Warranty Parts and Labor	2 Years
----------------------------------	---------



Installed in European style cabinets

