

T36FT810NS

36-INCH STAINLESS STEEL FREESTANDING FRENCH DOOR BOTTOM FREEZER

MASTERPIECE® SERIES HANDLES



Image shown is not final



Also Available In:
T36FT820NS – Professional Series Handles

FEATURES & BENEFITS

- Best in class lighting: see everything with fully illuminated back panel and adjustable theater lighting
- Stainless steel drawer protection: easily removable stainless steel mats make drawers easy to clean
- Dual evaporator, dual compressor
- Internal ice and water provides easy access with a clean exterior
- Thermafresh: humidity and temperature control combined

TEMPERATURE RANGES

Refrigerator	36°F (2°C) to 46°F (8°C)
SuperCool	36°F (2°C) for Approximately 6 Hours
Energy Saving (Economy) Mode	Refrigerator: 45°F (7°C) Freezer: 3°F (-16°C)
Freezer	-11°F (-24°C) to 7°F (-14°C)
SuperFreeze®	-22°F (-30°C) for Approximately 52 Hours

GENERAL PROPERTIES

Home Connect™ (Wi-Fi Enabled)	Yes
Full 72" Height and True Counter-Depth for Built-In Appearance	Yes
Carbon Air Filter	Yes
Ethylene Filter	Yes
Lighting	LED Recessed Side Light Bars & Fully Illuminated Back Panel
Dual Compressors / Evaporators	Yes
Refrigerator Shelves	5
Adjustable Shelves – Refrigerator	4
Shelf Material	Glass w/Aluminum Profile
ThermaFresh Temperature & Humidity Managed Drawers	2
ThermaFresh Mats	2
Door Bins – Refrigerator	4
Gallon Door Bins – Refrigerator	2
Defrost Process – Freezer	Automatic
Freezer Drawers	3
Internal Water Dispenser	Yes
Water Filter	Yes
Ice Maker with Diamond Ice System	Yes
Door Open Alarms	Yes
SuperCool	Yes
SuperFreeze®	Yes
Special Modes	Sabbath, Economy, Vacation

CAPACITY

Total Capacity (cu. ft.)	20.8 cu. ft.
Refrigerator / Freezer Capacity (cu. ft.)	14.8 / 6.0 cu. ft.

TECHNICAL DETAILS

Current (A) / Volts (V) / Frequency (Hz)	15 A / 115 V / 60 Hz
Power Cord Length (in.)	91
Plug Type	120V-3 Prong

DIMENSIONS & WEIGHT

Appliance Dimensions (H x W x D) (in.)	72" * x 35 5/8" x 31 7/16"
Appliance Dimensions without Hinges and Doors (H x W x D) (in.)	71 1/2" x 35 5/8" x 24"***
Appliance Dimensions with Hinges and Doors, No Handles (H x W x D) (in.)	72" * x 35 5/8" x 28 3/4"
Required Cutout Size (H x W x D) (in.)	72" x 36" x 25"
Net / Gross Weight (lbs.)	350 / 368 lbs.

EFFICIENCY

ENERGY STAR® Qualified	Yes
Annual Energy Consumption	570 kWh / yr

*When leveling legs are fully extended, add 5/8" to overall height, total 72 5/8".

**The cutout depth of 25" includes the required 1" airflow. The electrical covers on the back of unit do not require additional depth.

PRELIMINARY

T36FT810NS

36-INCH STAINLESS STEEL FREESTANDING FRENCH DOOR BOTTOM FREEZER

MASTERPIECE® SERIES HANDLES



WARRANTY

Please see Use & Care Manual or Thermador website for statement of limited warranty.

CUTOUT DIMENSIONS

measurements in inches (mm)

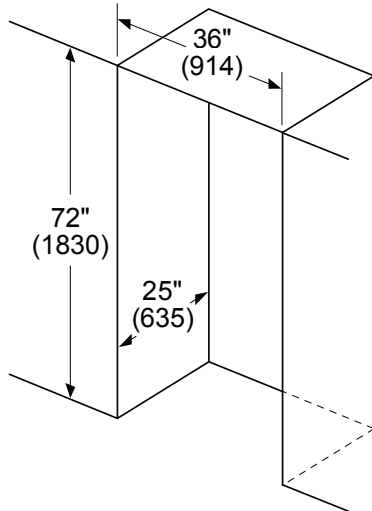

Leave ½" (12.7) gap at the top and 1" (25.4) behind the refrigerator for proper ventilation.

It is recommended that you do not install the refrigerator near a heat source such as a stove or a range.

TOP VIEW CLEARANCE

measurements in inches (mm)

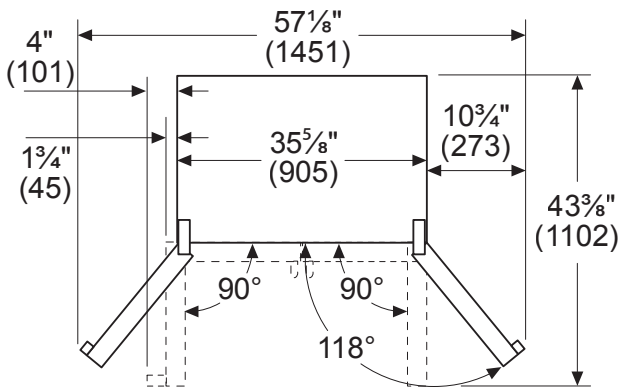

Drawers can be pulled out with door open to 90°. Drawers can be taken out with door completely opened.

PRELIMINARY

T36FT810NS

36-INCH STAINLESS STEEL FREESTANDING FRENCH DOOR BOTTOM FREEZER

MASTERPIECE® SERIES HANDLES



PRODUCT DIMENSIONS

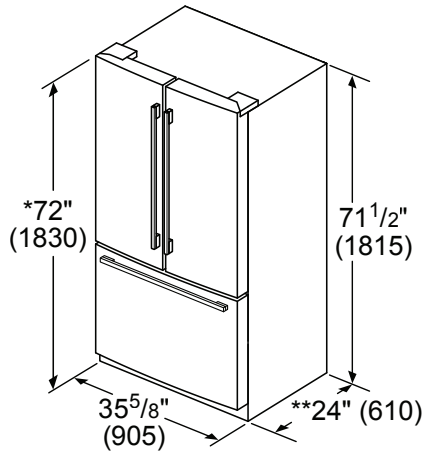

* Add $\frac{5}{8}$ " (17) with front leveling feet fully extended
 ** Add 1" (25) for fixed spacers on back

measurements in inches (mm)

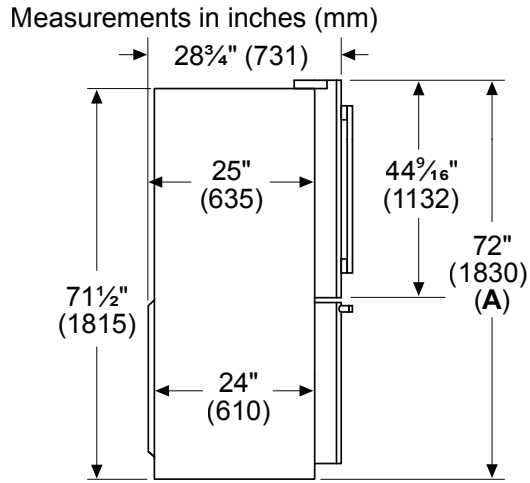

A: Add $\frac{5}{8}$ " (17) with front leveling feet fully extended

measurements in inches (mm)

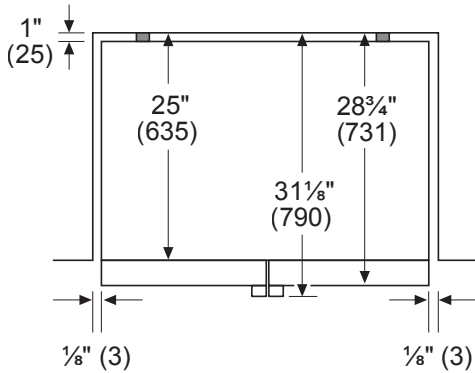

ACCESSORIES (OPTIONAL)

- | | | |
|---|---|--|
| REPLFLTR55
Replacement Water Filter | FPETHKT50
Ethylene Filter Starter Kit | FPETHRF50
Ethylene Filter Refill |
|---|---|--|

These warranties give you specific legal rights and you may have other rights that vary from state to state. Limited warranty from date of purchase. For complete warranty details, refer to your Use & Care manual, or ask your dealer.

Specifications are for planning purposes only. Refer to installation instructions and consult your countertop supplier prior to making counter opening. Consult with a heating and ventilation engineer for your specific ventilation requirements. For the most detailed information, refer to installation instructions accompanying product or write to Thermador indicating the model number. Specifications are correct at time of printing. Thermador reserves the right to change product specifications or design without notice. Some models are certified for use in Canada. Thermador is not responsible for products that are transported from the U.S. for use in Canada.

PRELIMINARY