



WATER CHILLER

CWT100

FEATURES:

- Compact, remote drinking water chiller
- For use with the following InSinkErator Hot/Cold faucets (sold separately):
 - HC1100; HC2200; HC2215; HC View; HC Wave
 - Note: Not recommended with HC3300
- For use with the following Cold Only faucet: C1100 (sold separately)
- Water temperature from faucet as low as 40°F (recorded in InSinkErator's controlled environment)
- Adjustable thermostat to control refrigeration system
- Welded water lines
- HFC refrigerant R-134a

MATERIAL:

- Stainless steel storage tank
- 1/4-inch OD stainless steel water tube connections
- White Powder coated galvanized steel cabinet with gray plastic front

WARRANTY:

We Come To You[®] 3-Year In-Home Limited Warranty.
Covers parts and labor.

The complete InSinkErator warranty is included in the Care & Use booklet with each unit.

CERTIFICATIONS:



Compressor H/P	1/20
Wattage	135 Watts
Voltage	115 Volts
Current	1.2 Amps
Approx Net Weight	30 lbs (13.6 kg)

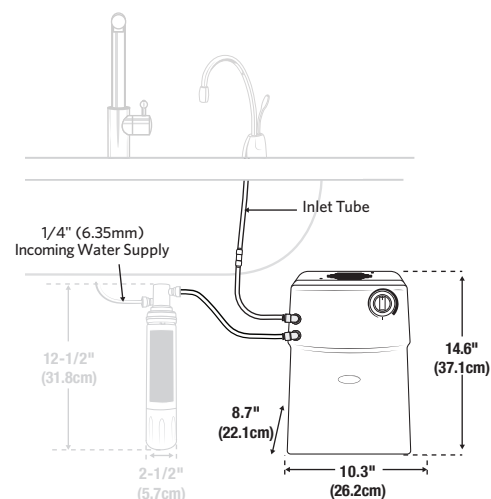

USA: 1.800.558.5700 www.insinkerator.com
CA: 1.800.561.1700 www.insinkerator.ca

WDT523-18E-95-90



InSinkErator may make improvements and/or changes in the specifications at any time, in its sole discretion, without notice or obligation and further reserves the right to change or discontinue models.

©2020 InSinkErator, InSinkErator[®] is a business unit of Emerson Electric Co. All rights reserved.