



U-LINE



NOT YOUR AVERAGE CUP OF JOE 15" COLD COFFEE DISPENSER

Enjoy creamy nitrogen-infused coffee and refreshing still cold-brew coffee on demand. Nitrogen-infused coffee delivers the ultimate experience by infusing thousands of micro-nitrogen bubbles as the coffee is dispensed. This creates a natural slightly sweet taste and thicker and smoother texture. Simply fill the keg with your favorite cold coffee or tea.

Coffee Shop Quality at Home

Nitrogen-Infused



Still Cold-Brew

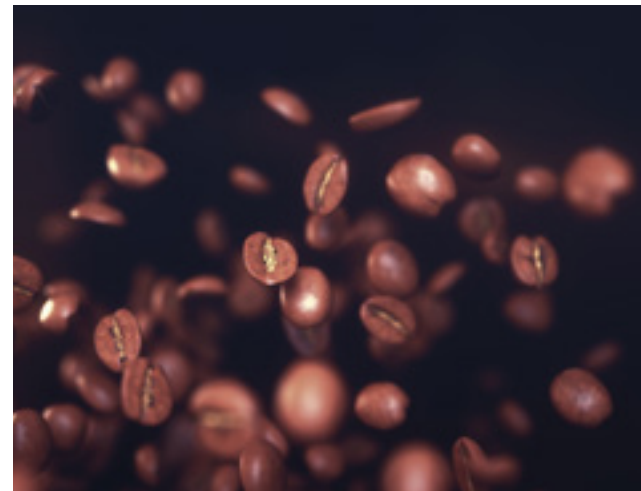



Coffee Shop Quality at Home

Enjoy creamy nitrogen-infused coffee and refreshing still cold-brew coffee on demand. Nitrogen-infused coffee delivers the ultimate experience by infusing thousands of micro-nitrogen bubbles as the coffee is dispensed. This creates a natural slightly sweet taste and thicker and smoother texture.

Simply fill the keg with your favorite cold coffee or tea.

Key Features

- Dispenses still cold-brew and nitro-infused coffee
- Includes: refrigeration cabinet, dispensing tower with two tap heads, one 2.5 gallon coffee keg, nitrogen regulator, tubing and hardware, black tap handles, drip tray
- Convection cooling system provides a quick cool down and consistent temperature
- Temperature range: 34°F - 60°F
- Full-depth lower interior
- Volume of 3.6 cu ft holds two 2.5, 3, or 5 gallon coffee kegs and nitrogen tank
- Stainless steel cabinet, grille, and full-wrap door
- Black interior
- Removable lower interior stainless steel liner
- Digital touch pad control with blue LED display
- Stainless steel handle (7/8" diameter)
- Field reversible door is shipped right-hand hinged
- Built-in or freestanding
- Adjustable leveling legs

MODEL DETAILS

Model	Voltage/Hz	Door Swing	Finish	Shipping Weight
UHDE215-SS03A	115 / 60	Field Reversible	Stainless Solid	80 lb

ACCESSORIES

Model	Description	Finish	Shipping Weight
ULANITROTANK	22 cu ft aluminum nitro tank	N/A	10 lb
ULACOFFEEKEG	2.5 gal coffee keg	N/A	6 lb
ULACASTERS	Set of 4 casters	N/A	6 lb
ULACOFFEECLEAN	Coffee Dispenser Cleaner (1 box of 5 packets)	N/A	1 lb

Front

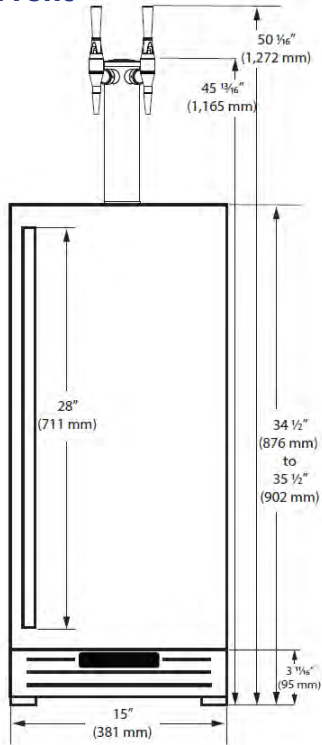

Side

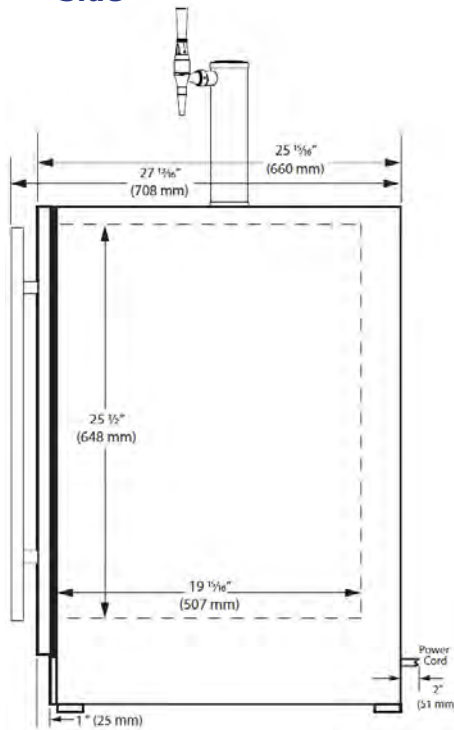

Top

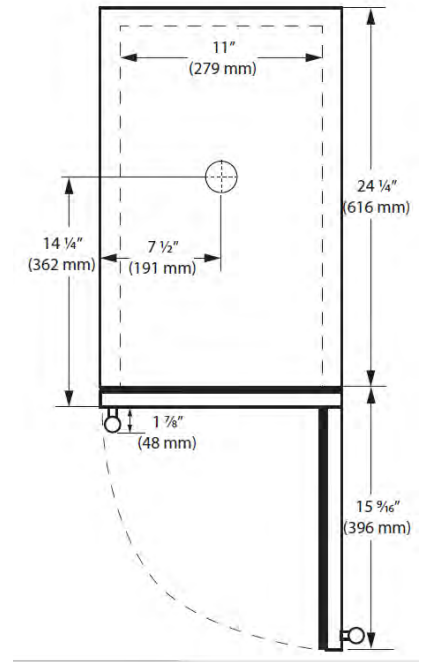

Specifications

Model	HDE215
Amps: Running	1.2
Capacity: Volume (cu ft)	3.6
Capacity: Keg (2.5 gal)	2
Dimensions: Product Depth	25 15/16" / 660 mm
Dimensions: Product Height (Min.)	34 1/2" / 902 mm
Dimensions: Product Width	15" / 381 mm
Energy Consumption: Avg. Per Year	290 kWh
Product Weight	80 lb
Refrigerant Type	R600a
Temperature Range	34°F - 60°F

Back

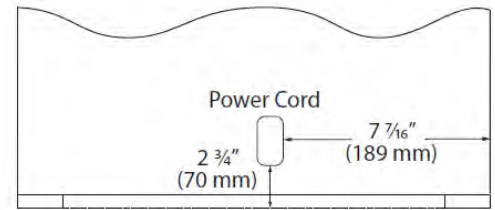

Cabinet Cut-Out

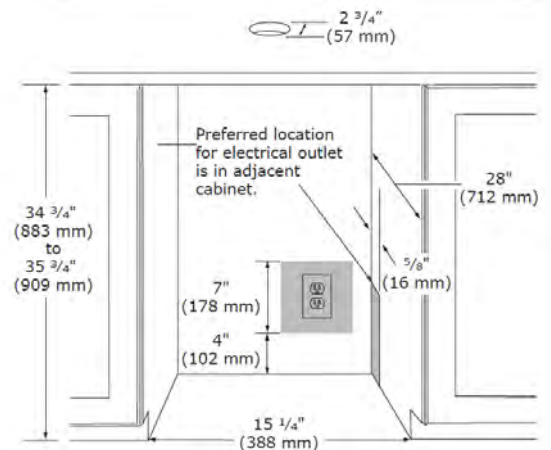

Installation Notes

- Power cord extends 2" beyond total depth
- No additional clearance is needed for ventilation
- Do not obstruct front grille air flow

Warranty

- 1 Year (parts & labor) / 5 year sealed system (parts)
- **2 Year (parts & labor) / 5 year sealed system (parts) upgrade at no cost with product registration**



See complete warranty for details



Please visit u-line.com to view this model's User Guide & Service Manual. All Specifications are subject to change without notice.