

**TOTO®**

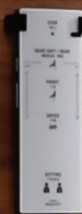

**NEW**

**washlet®**  
G400

REPLACES THE G500

# WASHLET® G400

## INTEGRATED TOILET

MS920CEMFG



PREMIST  
FEATURE

NO SIDE  
COVER

### FEATURES

- 3D Tornado Flush™ system, high-efficiency (1.28GPF/4.8LPF and 0.9GPF/3.4LPF)
- CeFIONtect™ ceramic glaze minimizes debris and mold from sticking to porous, ceramic surfaces
- Universal Height
- Skirted design
- Elongated front bowl
- 12" Rough-In
- Auto open/close lid, auto flush
- Multifunction remote control, with illuminated touch pad
- Heated seat with temperature control
- Water Premist™ of bowl before each use
- Adjustable spray position
- Washlet with three wash modes (front, rear, soft)
- Oscillating and pulsating comfort washing
- Energy saver timer
- Built-in air purifying system

### SPECIFICATIONS

<b>Water Use</b>	1.28 GPF/4.8 LPF & 0.9 GPF/3.4 LPF
<b>Flush System</b>	3D Tornado Flush
<b>Water Pressure</b>	Min 7.25 PSI (0.05MPa) Flowing Max 108.75PSI (0.75MPa) Static
<b>Water Surface</b>	5-3/8" (137 mm) x 4-3/16" (106 mm)
<b>Trap Diameter</b>	2-3/4" (70 mm)
<b>Rough-In</b>	12"
<b>Trap Seal</b>	2-1/8" (54 mm)
<b>Material</b>	Bowl: Vitreous china Seat and cover: Plastic
<b>Shipping Weight</b>	Top Unit - SN920M: 17.6lbs Bowl Unit - CT920CEMFG: 106lbs
<b>Shipping Dimensions</b>	SN920M: 20-5/8" X 34-13/16" X 8-13/16" CT920CEMFG: 18-13/16" X 33-1/4" X 24-7/8"

*Dimensions and specifications are subject to change without notice.*

### PRODUCT DIMENSIONS

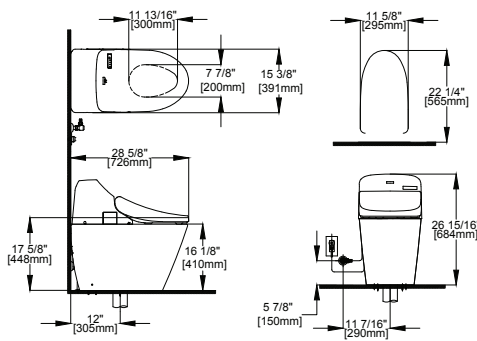

AVAILABLE  
COLORS



#01  
Cotton



#12  
Sedona Beige

## PREMIST TECHNOLOGY

The new Washlet G400 features a cleaning technology that utilizes the incoming water supply to mist the bowl before use. The dampened surface aids in the elimination of waste approximately 80 percent better than a dry bowl, making it easier to clean.

